

# QCD Systems Inc

## The Try Z Seminar

---

### *The first module in the QCDSM system of management*

#### **Uniquely Designed**

The QCD Try Z seminar is uniquely designed to take executives, managers and company personnel who will influence change through an introspective four-day seminar. Delegates will explore and develop an understanding of the challenges involved in creating a Continuous Improvement environment.

#### **Hands-on Experience**

Instead of being lectured to, Delegates explore a hands-on learning of a process about which, initially, they know very little. They take this process through three continuous improvement cycles.

The group begins by formalizing the process, then testing the results. The initial production run takes approximately one hour after which delegates usually identify from 150 to 200 defects in the vehicle they produced. At this time, the T.Q.M. principles are applied and continuous improvement is made to the procedures used.

#### **Appreciation for Challenges**

Among the results of this training is the development of a tremendous appreciation for the challenges

involved in creating an environment for continuous improvement. When delegates leave the Try Z Seminar they will know how to begin to create the environment which will help the company apply the QCDSM principles.

#### **Some challenges**

- An appreciation of the quantity of detail involved in managing processes as well as people;
- The realization that everything is a process;
- Understanding the importance of the written Detail Process Sheet to obtain continuous improvement;
- The discipline of sticking to the environmental changes which one is trying to create;
- Building teamwork as each team member improves his or her process based on its Quality, Cost, and Delivery and Safety measurements.

#### **Who should attend?**

Those people who are going to become the 'instruments of change' in a company would be the first to benefit from this training. Green Room leaders and their backups, their Supervisors and so on, up the chain of command. Support People important to the functioning of the facility should also be included.

Many companies use this seminar to generate what we refer to as the 'critical mass' in terms of excitement, knowledge and understanding. It is



from this that the 'champions of the process'

### The Try Z name

The name **TRY Z** is derived from a process common to the automobile industry. It refers to a method whereby model changes for production are made.

Try Z (or 'Trial Zero') is a three-step procedure.

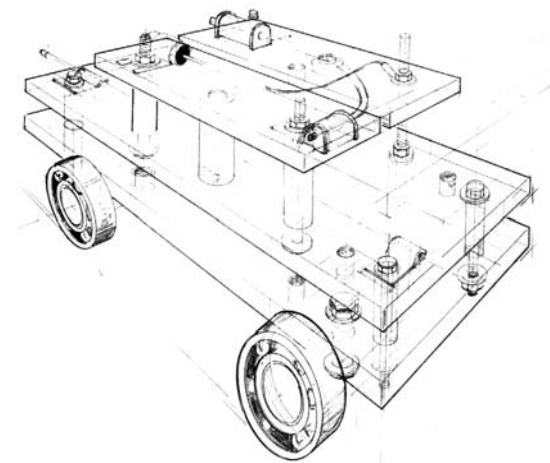

When changes to a current model unit or to a new model unit at pre-production stage are imminent, the model unit is laid out in an assembly hall separate from normal production. All concerned with the development of that model unit, including production personnel, begin to assemble the unit from scratch, documenting their activities.

The purpose of this first step is simply to see if the parts fit together, how they fit together and if the unit finally works. The documentation - Detailed Process Sheet (DPS) - is their record of the assembly activity.

They then evaluate what they have done and make necessary changes.

Copyright © Peter J Paola  
January, 2002  
All rights reserved.

Using the original document to make whatever changes are necessary, they then proceed with the second build.

Following the same procedure as before, they make a third attempt incorporating the changes into the assembly process. The operators for that new model are then trained from the development document (DPS) and the new models are introduced gradually until the last of the previous models are worked out and the new models have taken their place on the assembly.

The seminar follows this process.

### The 'Executive' Try Z

QCDSM is the process that addresses the fundamental challenge of involving all your Employees in the drive for Productivity and Efficiency. This leads to high morale and the remarkable involvement of all your People in helping to achieve your goals. It is the process whereby the People of a company are enabled, through their participation in decision making, problem solving, safety enhancement and delivering improved efficiencies and productivity, to reach the **next step** in your company's push for excellence and growth.

As an introduction to QCDSM as a whole and the Try Z Seminar in particular, we have developed what we have called the **'Executive' Try Z!**

This is a **3 day seminar** compared to the standard 4 day training. It is directed specifically to those key persons in your company who will need to promote and drive the full

105 Townline Road,  
Vernon Hills, Illinois 60061, USA  
.www.qcdsm.com E-mail qcdpjp@ix.netcom.com  
Tel. (847) 404 9887



implementation of the QCDSM process.

Our web site: [www.qcdsm.com](http://www.qcdsm.com)

contains a great deal of this information with explanations of how this works. **However, we will be privileged to visit with you, at our expense, to further explain the process, it's implementation and to answer the questions you may have.**

We look forward to your call or e-mail.

**The use of this plastic model unit (see picture over) to demonstrate the QCDSM process is designed to help all understand that if they are able to manage the requirements for building 15 of these to specifications and within the time frame, the lessons learned can be applied to any industry or business or process.**

### **QCDSM as the management tool for the maintenance of ISO 9000**

Many Companies are embracing the ISO 9000 process as they enter into the global dimensions of doing business.

The success of this movement requires that a Quality Management System be established within their organization together with a method of managing this system.

Based on the Eight Quality Management principles incorporated into the ISO 9000 2000 process it is our belief that the QCDSM System, once in place, provides the framework for the management of the ISO 9000 2000 system.

The management and maintenance of an initiative, once implemented, is a critical requirement because, once

Copyright © Peter J Paola  
January, 2002  
All rights reserved.

embarked upon, the ability of the facility to succeed with the initiative depends on how it is integrated into the daily business of that facility.

QCDSM initiates a cultural change in the way in which a Company does business. The integration of QCDSM and ISO 9000 2000 will enhance this change and move the Company forward on it's road to excellence.

There is a caveat as well: QCDSM and ISO 9000 and in fact, any initiative embraced by a company, must be integrated as part of the culture of a company for it to be successful. QCDSM is designed to facilitate this process of integration.

We will happily explain how QCDSM ensures that the integration of the ISO 9000 process with QCDSM becomes a cultural part of the way in which business is conducted on a daily basis. The Try Z seminar is ideally suited to demonstrate how this management process works.

**You cannot manage  
what you do not  
measure!**

Our third module deals with the Green Room Meeting purpose and structure.

105 Townline Road,  
Vernon Hills, Illinois 60061, USA  
.www.qcdsm.com E-mail [qcdpjp@ix.netcom.com](mailto:qcdpjp@ix.netcom.com)  
Tel. (847) 404 9887

